

# S1215 12A SCRs

## FEATURES

- High thermal cycling performance
- High voltage capacity
- Very high current surge capability

## APPLICATIONS

- Line rectifying 50/60 Hz
- Softstart AC motor control
- DC Motor control
- Power converter
- AC power control
- Lighting and temperature control

## Parameters Summary

- VD/VR:600V/800V
- IT(RMS):12A
- IGT :3~15mA

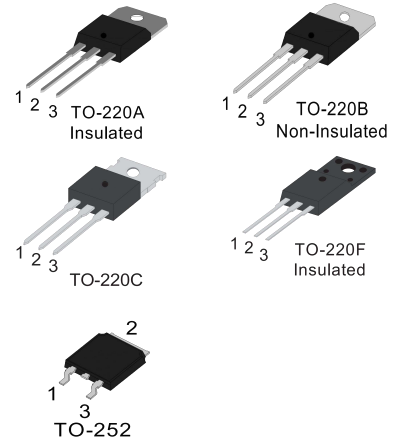
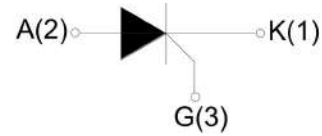

ABSOLUTE MAXIMUM RATINGS			
Parameter	Symbol	Value	Unit
Storage junction temperature range	T <sub>stg</sub>	-40 ~150	°C
Operating junction temperature range	T <sub>j</sub>	-40~125	°C
Repetitive peak off-state voltage (T =25°C)	V <sub>DRM</sub>	600/800	V
Repetitive peak reverse voltage (T =25°C)	V <sub>RRM</sub>	600/800	V
Non repetitive surge peak Off-state voltage	V <sub>DSM</sub>	V <sub>DRM</sub> +100	V
Non repetitive peak reverse voltage	V <sub>RSM</sub>	V <sub>RRM</sub> +100	V
RMS on-state current (T =110°C)	I <sub>T(RMS)</sub>	12	A
Non repetitive surge peak on-state current(180° conduction angle, F=50Hz)	I <sub>TSM</sub>	140	A
Average on-state current (180° conduction angle)	I <sub>T(AV)</sub>	8	A
I <sup>2</sup> t value for fusing (tp=10ms)	I <sup>2</sup> t	98	A <sup>2</sup> S
Critical rate of rise of on-state current(I =2×IGT, tr ≤ 100 ns)	dI/dt	50	A/μS
Peak gate current	I <sub>GM</sub>	4	A
Average gate power dissipation	P <sub>G(AV)</sub>	1	W

Thermal Resistances				
Symbol	Parameter		Value	Unit
Rth(j-c)	Junction to case (DC)	TO-220A	2.1	°C/W
		TO-220B	1.3	
		TO-220C	1.3	
		TO-220F	2.5	
		TO-252	1.8	

ELECTRICAL CHARACTERISTICS (T=25°C unless otherwise specified)				
Symbol	Test Condition		Value	Unit
$I_{GT}$	V = 12V R = 140Ω	MAX.	3~15	mA
$V_{GT}$		MAX.	1.3	V
$V_{GD}$	V <sub>D</sub> =V <sub>DRM</sub> T <sub>j</sub> =125°C R=1KΩ	MIN.	0.2	V
$I_L$	I <sub>G</sub> =1.2I <sub>GT</sub>	MAX.	60	mA
$I_H$	I <sub>T</sub> =50mA	MAX.	40	mA
dV/dt	V <sub>D</sub> =2/3V <sub>DRM</sub> Gate Open T <sub>j</sub> =125°C	MIN.	400	V/μs

STATIC CHARACTERISTICS				
Symbol	Parameter		Value(MAX. )	Unit
$V_{TM}$	ITM = 24A tp=380μs	T <sub>j</sub> = 25°C	1.55	V
$I_{DRM}$	V <sub>D</sub> =V <sub>DRM</sub> V <sub>R</sub> =V <sub>RRM</sub>	T <sub>j</sub> = 25°C	5	μA
$I_{RRM}$		T <sub>j</sub> = 125°C	2	mA

### Ordering Information Scheme

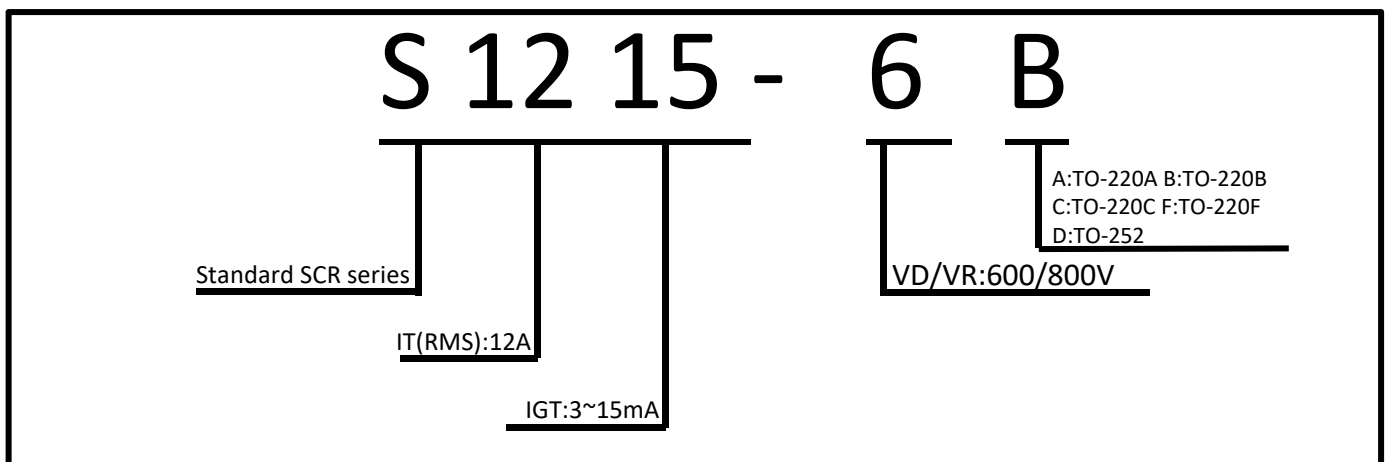

### TO-220A Package Mechanical Data

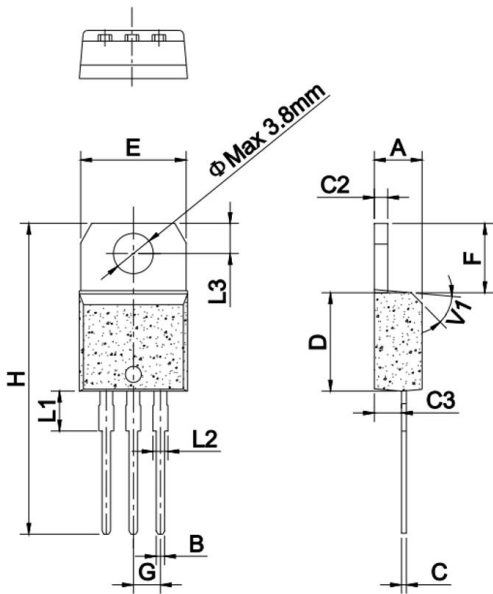

Ref.	Dimensions					
	Millimeters			Inches		
	Min.	Typ.	Max.	Min.	Typ.	Max.
A	4.40		4.60	0.173		0.181
B	0.61		0.88	0.024		0.035
C	0.46		0.70	0.018		0.028
C2	1.21		1.32	0.048		0.052
C3	2.40		2.72	0.094		0.107
D	8.60		9.70	0.339		0.382
E	9.80		10.4	0.386		0.409
F	6.55		6.95	0.258		0.274
G		2.54			0.1	
H	28.0		29.8	1.102		1.173
L1		3.75			0.148	
L2	1.14		1.70	0.045		0.067
L3	2.65		2.95	0.104		0.116
V1		45°			45°	

### TO-220B Package Mechanical Data

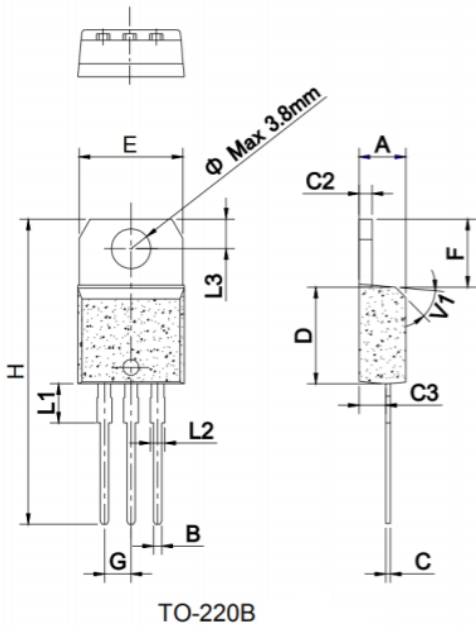

Ref.	Dimensions					
	Millimeters			Inches		
	Min.	Typ.	Max.	Min.	Typ.	Max.
A	4.20		4.50	0.165		0.177
B	0.61		0.88	0.024		0.035
C	0.40		0.55	0.015		0.021
C2	1.25		1.40	0.049		0.055
C3	2.40		2.72	0.094		0.107
D	8.60		9.70	0.339		0.382
E	9.60		10.4	0.378		0.409
F	6.25		7.05	0.244		0.260
G		2.54			0.1	
H	28.0		29.8	1.102		1.173
L1		3.9			0.153	
L2	1.14		1.70	0.045		0.067
L3	2.65		2.95	0.104		0.116
V1		45°			45°	

### TO-220C Package Mechanical Data

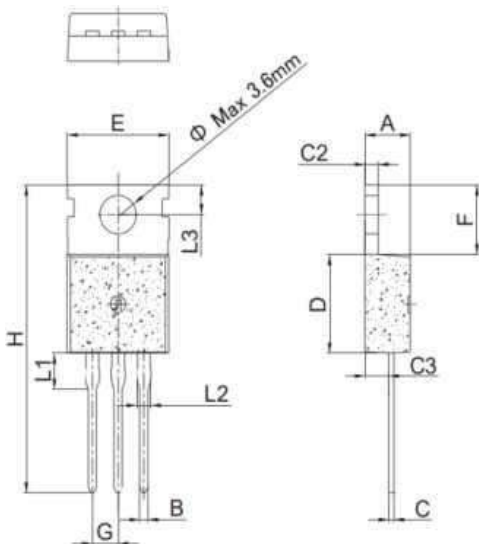

Ref.	Dimensions					
	Millimeters			Inches		
	Min.	Typ.	Max.	Min.	Typ.	Max.
A	4.40		4.60	0.		0.
B	0.70		0.90	0.0280.		0.0350.
C	0.45		0.60	0.0180.		0.0240.
C2	1.30		1.48	0.0510.		0.0590.
C3	2.20		2.60	0.0870.		0.1020.
D	8.90		9.90	0.3500.		0.3900.
E	9.90		10.3	0.3900.		0.4060.
F	6.30		6.90	0.248		0.272
G		2.54			0.1	
H	28.0		29.8	1.102		1.173
L1		3.39			0.133	
L2	1.14		1.70	0.045		0.067
L3	2.65		2.95	0.104		0.116
e		3.6			0.142	

## TO-220F Package Mechanical Data

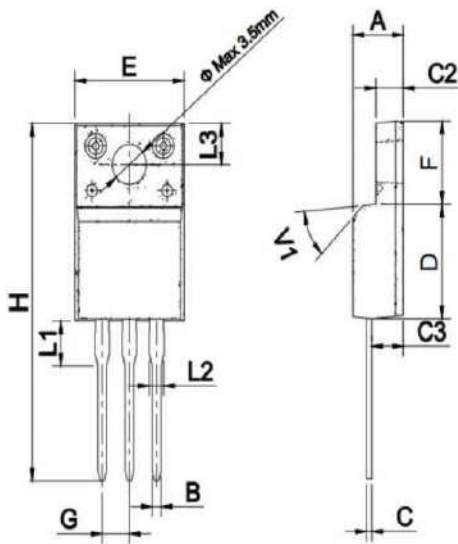

Ref.	Dimensions					
	Millimeters			Inches		
	Min.	Typ.	Max.	Min.	Typ.	Max.
A	4.50		4.90	0.		0.
B	0.74	0.80	0.83	0.029	0.031	0.033
C	0.47		0.65	0.019		0.026
C2	2.50		3.10	0.100		0.122
C3	2.40		2.80	0.095		0.110
D	8.60		8.90	0.338		0.350
E	9.80		10.4	0.386		0.410
F	6.70		7.50	0.264		0.295
G		2.54		0.100	0.1	0.268
H	28.0		29.8	1.102		1.173
L1		3.63			0.143	
L2	1.14		1.70	0.045		0.067
L3		3.30			0.130	
V1		45°			45°	

## TO-252 Package Mechanical Data

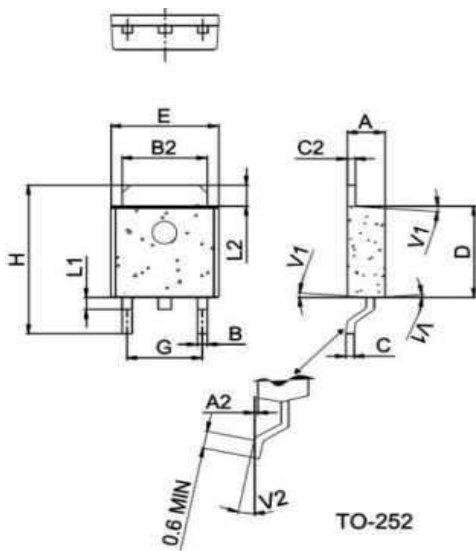

Ref.	Dimensions					
	Millimeters			Inches		
	Min.	Typ.	Max.	Min.	Typ.	Max.
A	2.20		2.40	0.086		0.095
A2	0.03		0.23	0.001		0.009
B	0.55		0.65	0.022		0.026
B2	5.10		5.40	0.200		0.213
C	0.45		0.62	0.018		0.024
C2	0.71		0.99	0.028		0.039
D	6.00		6.20	0.236		0.244
E	6.40		6.70	0.252		0.264
G	4.40		4.70	0.173		0.185
H	9.35		10.60	0.368		0.417
L1	1.30		1.70	0.051		0.067
L2	1.37		1.50	0.054		0.059
V1		4				
V2	0		8	0		8

FIG.1 Maximum power dissipation versus Average on-state current

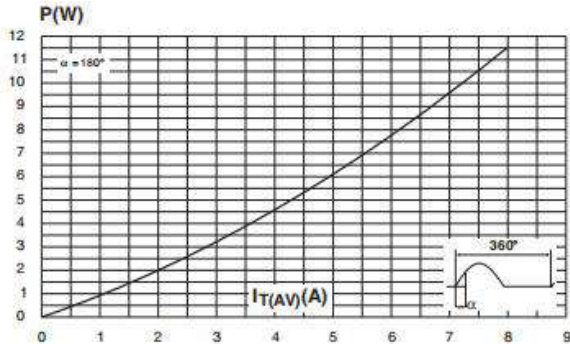

FIG.2: on-state current versus case temperature

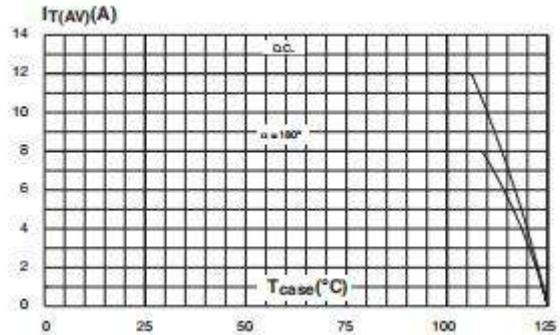

FIG.3: Surge peak on-state current versus number of cycles

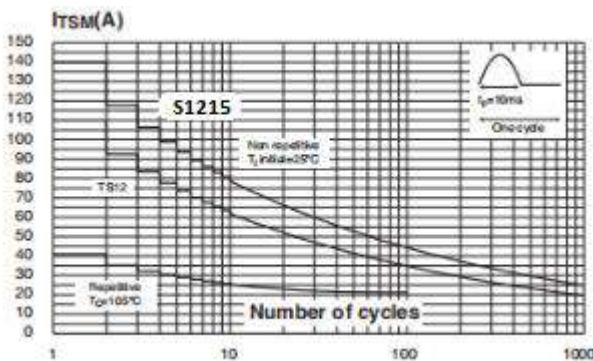

FIG.4: On-state characteristics (maximum values)

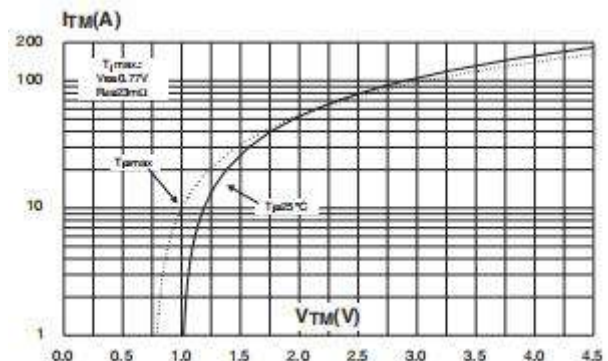

FIG.5: Non-repetitive surge peak on-state current for a sinusoidal pulse with width  $t_p < 10\text{ms}$ , and corresponding value of  $I_2 t$  ( $di/dt < 50\text{A}/\mu\text{s}$ )

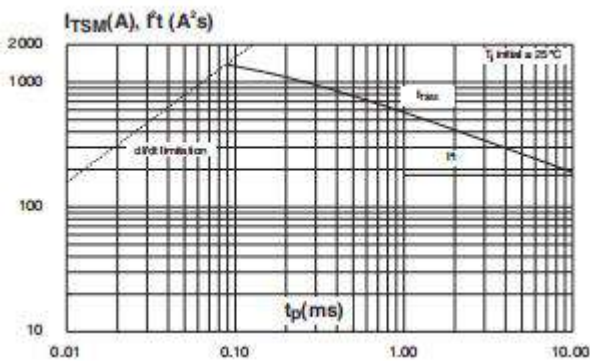

FIG.6: Relative variations of gate trigger current holding current and latching current versus junction temperature

