

# T25 25A TRIACs

## FEATURES

- Glass Passivated Junctions
- High voltage and surge capability
- Low Thermal Resistance and Durability
- Triggering in three quadrants

## APPLICATIONS

- Static relays
- Heating regulation
- In-duction motor starting circuits
- Phase control operation in light dimmers
- Motor speed controllers

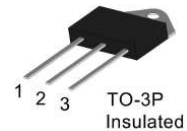
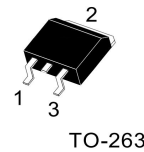
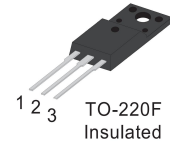
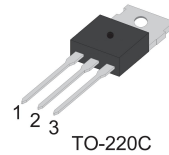
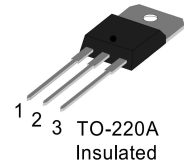
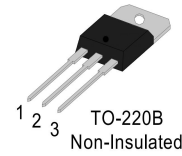
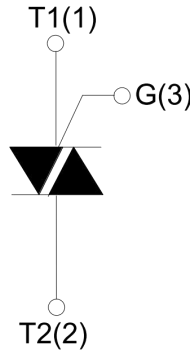

## Parameters Summary

VD/VR:600/800/1200V

IT(RMS):25A

IGT:05 to 50mA

## ABSOLUTE MAXIMUM RATINGS

Parameter	Symbol	Value	Unit
Storage junction temperature range	T <sub>stg</sub>	-40~150	°C
Operating junction temperature range	T <sub>j</sub>	-40~150	°C
Repetitive peak off-state voltage (T =25°C)	V <sub>DRM</sub>	600/800/1200	V
Repetitive peak reverse voltage (T =25°C)	V <sub>RRM</sub>	600/800/1200	V
RMS on-state current (TC=100°C)	I <sub>T(RMS)</sub>	25	A
Non repetitive surge peak on-state current (full cycle, F=50Hz)	I <sub>TSM</sub>	250	A
I <sup>2</sup> t value for fusing (tp=10ms)	I <sup>2</sup> t	340	A <sup>2</sup> S
Critical rate of rise of on-state current(I =2×I <sub>GT</sub> )	di/dt	50	A/μS
Peak gate current	I <sub>GM</sub>	4	A
Peak gate power dissipation	P <sub>GM</sub>	10	W
Average gate power dissipation	P <sub>G(AV)</sub>	1	W

## Thermal Resistances

Symbol	Parameter	Value	Unit
R <sub>th(j-c)</sub>	Junction to case (DC)	TO-3P	1.0
		TO-220A	1.5
		TO-220B/C	1.1
		TO-220F	1.7
		TO-263	0.85

**ELECTRICAL CHARACTERISTICS (T=25°C unless otherwise specified)**

Symbol	Test Condition	Quadrant		Value				Unit
				5	10	35	50	
$I_{GT}$	$V_D=12V, I_T=0.1A, T_j=25^\circ C$	I II III	MAX.	5	10	35	50	mA
$V_{GT}$		I II III	MAX.	1.3				V
$V_{GD}$	$V_D=V_{DRM}, T_j=125^\circ C$	I II III	MIN.	0.2				V
$I_L$	$I_G=1.2I_{GT}$	I-III	MAX.	20	30	50	80	mA
		II		30	40	60	100	
$I_H$	$I_T=100mA$		MAX.	50	20	40	60	mA
dV/dt	$V_D=2/3V_{DRM}$ Gate Open $T_j=125^\circ C$		MIN.	100	200	500	1000	V/ $\mu s$

**STATIC CHARACTERISTICS**

Symbol	Parameter		Value(MAX. )	Unit
$V_{TM}$	$I_{TM}=35A$ $t_p=380\mu s$	$T_j=25^\circ C$	1.55	V
$I_{DRM}$	$V_D=V_{DRM}, V_R=V_{RRM}$	$T_j=25^\circ C$	5	$\mu A$
$I_{RRM}$		$T_j=125^\circ C$	3	mA

Ordering Information Scheme

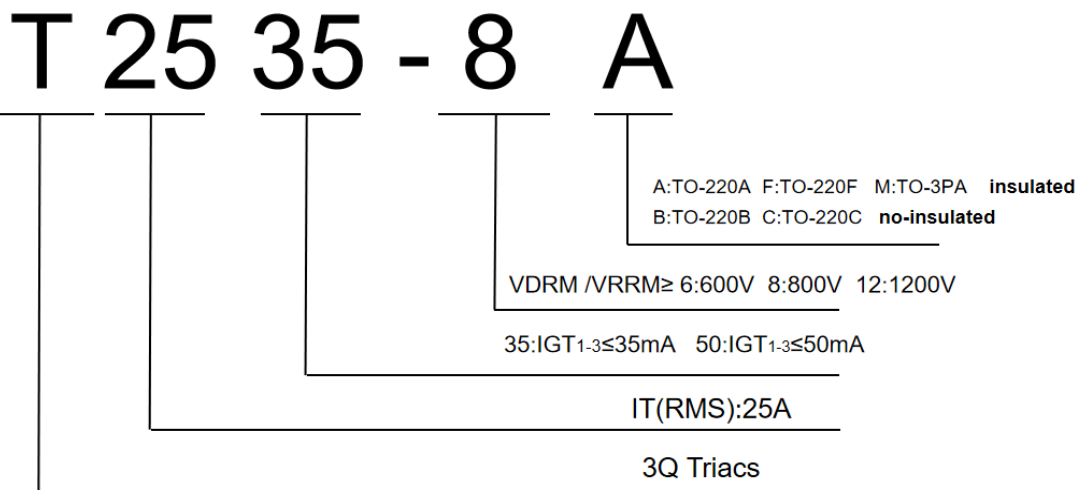

Part	Package	Marking	Packing method
T2535-8A	TO-220A	T2535-8A	Tube
T2535-8B	TO-220B	T2535-8B	Tube
T2535-8C	TO-220C	T2535-8C	Tube
T2535-8F	TO-220F	T2535-8F	Tube
T2535-8Z	TO-263	T2535-8Z	Tape and Reel

## TO-220A Package Mechanical Data

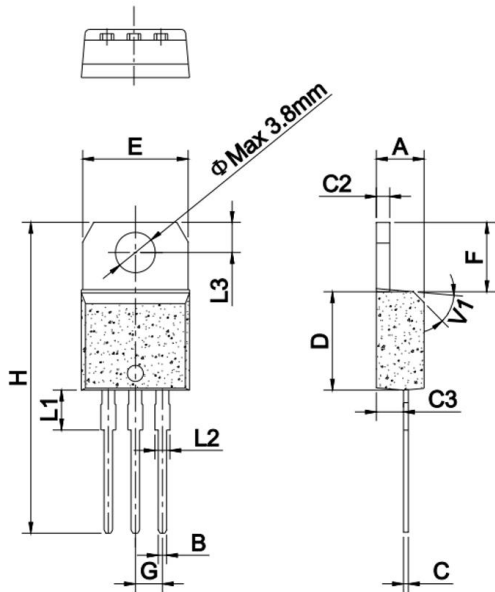

Ref.	Dimensions					
	Millimeters			Inches		
	Min.	Typ.	Max.	Min.	Typ.	Max.
A	4.40		4.60	0.173		0.181
B	0.61		0.88	0.024		0.035
C	0.46		0.70	0.018		0.028
C2	1.21		1.32	0.048		0.052
C3	2.40		2.72	0.094		0.107
D	8.60		9.70	0.339		0.382
E	9.80		10.4	0.386		0.409
F	6.55		6.95	0.258		0.274
G		2.54			0.1	
H	28.0		29.8	1.102		1.173
L1		3.75			0.148	
L2	1.14		1.70	0.045		0.067
L3	2.65		2.95	0.104		0.116
V1		45°			45°	

## TO-220B Package Mechanical Data

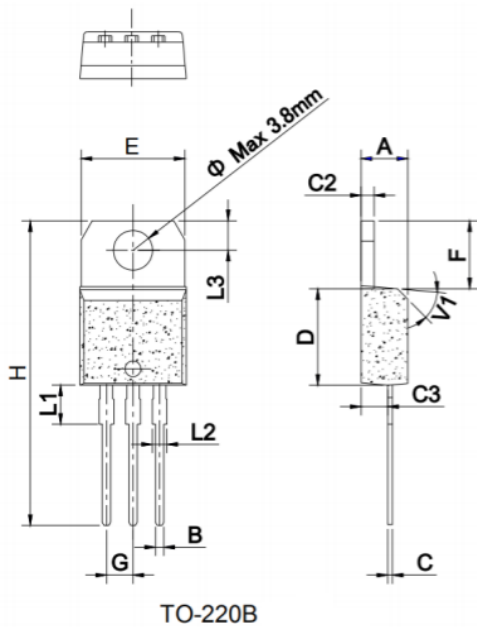

Ref.	Dimensions					
	Millimeters			Inches		
	Min.	Typ.	Max.	Min.	Typ.	Max.
A	4.20		4.50	0.165		0.177
B	0.61		0.88	0.024		0.035
C	0.40		0.55	0.015		0.021
C2	1.25		1.40	0.049		0.055
C3	2.40		2.72	0.094		0.107
D	8.60		9.70	0.339		0.382
E	9.60		10.4	0.378		0.409
F	6.25		7.05	0.244		0.260
G		2.54			0.1	
H	28.0		29.8	1.102		1.173
L1		3.9			0.153	
L2	1.14		1.70	0.045		0.067
L3	2.65		2.95	0.104		0.116
V1		45°			45°	

## TO-220C Package Mechanical Data

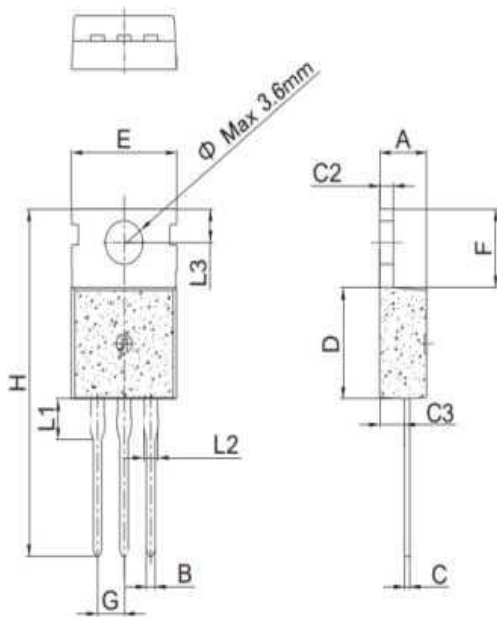

Ref.	Dimensions					
	Millimeters			Inches		
	Min.	Typ.	Max.	Min.	Typ.	Max.
A	4.40		4.60	0.173		0.181
B	0.70		0.90	0.028		0.035
C	0.45		0.60	0.018		0.024
C2	1.30		1.48	0.048		0.052
C3	2.20		2.60	0.087		0.102
D	8.90		9.90	0.350		0.390
E	9.90		10.3	0.390		0.406
F	6.30		6.90	0.248		0.272
G		2.54			0.1	
H	28.0		29.8	1.102		1.173
L1		3.39			0.133	
L2	1.14		1.70	0.045		0.067
L3	2.65		2.95	0.104		0.116
e		3.6			0.142	

## TO-220F Package Mechanical Data

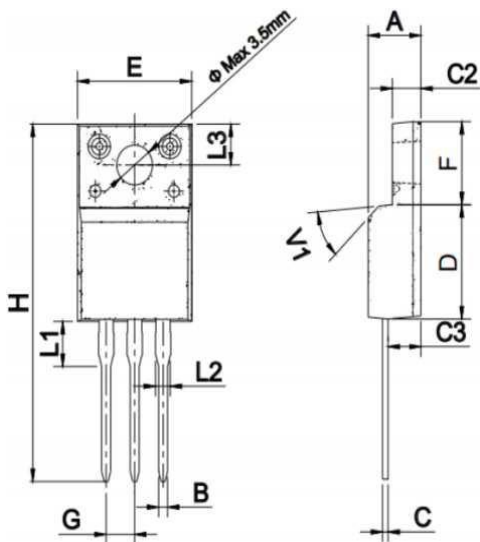

Ref.	Dimensions					
	Millimeters			Inches		
	Min.	Typ.	Max.	Min.	Typ.	Max.
A	4.50		4.90	0.177		0.193
B	0.74	0.80	0.83	0.029	0.031	0.033
C	0.47		0.65	0.019		0.026
C2	2.50		3.10	0.096		0.108
C3	2.40		2.80	0.102		0.118
D	8.60		8.90	0.346		0.366
E	9.80		10.4	0.386		0.410
F	6.70		7.50	0.252		0.268
G		2.54			0.1	
H	28.0		29.8	1.102		1.173
L1		3.63			0.143	
L2	1.14		1.70	0.045		0.067
L3		3.30			0.130	
V1		45°			45°	

## TO-263 Package Mechanical Data

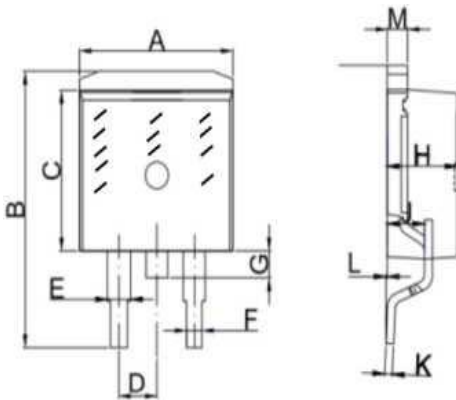

Ref.	Dimensions					
	Millimeters			Inches		
	Min.	Typ.	Max.	Min.	Typ.	Max.
A	9.90		10.5	0.390		0.402
B	14.70		15.80	0.579		0.622
C	8.8		9.2	0.37		0.378
D		2.54			0.100	
E	1.20		1.40	0.047		0.055
F	0.75		0.85	0.029		0.033
G			1.75			0.069
H	4.40		4.70	0.173		0.185
J	2.30		2.70	0.091		0.106
K	0.38		0.55	0.015		0.022
L	0		0.25	0	0.004	0.010
M	1.25		1.35	0.049		0.053

## TO-3P Package Mechanical Data

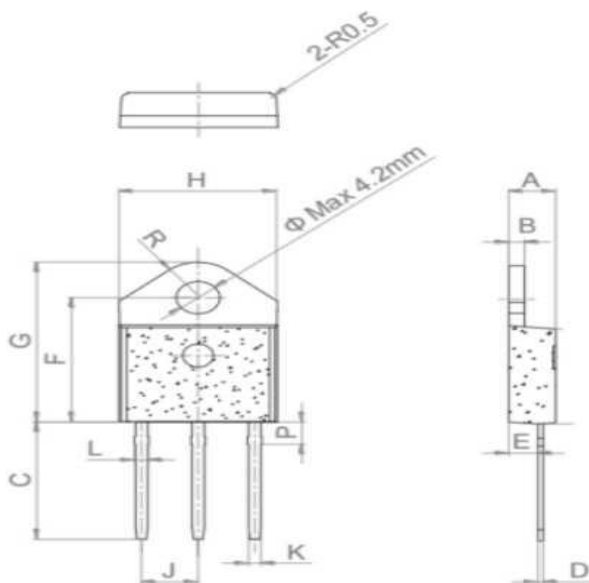

Ref.	Dimensions					
	Millimeters			Inches		
	Min.	Typ.	Max.	Min.	Typ.	Max.
A	4.40		4.60	0.173		0.181
B	1.40		1.60	0.055		0.062
C	15.48		15.88	0.609		0.625
D	0.50		0.70	0.019		0.027
E	2.70		2.90	0.106		0.114
F	15.92		16.32	0.626		0.642
G	20.27		20.67	0.798		0.813
H	15.15		15.35	0.590		0.604
J		5.45			0.214	0.216
K	1.10		1.30	0.043		0.051
L	1.15		1.35	0.045		0.053
P	2.68		3.08	0.105		0.121
R		4.20			0.165	

FIG.1 Maximum power dissipation versus on-state current

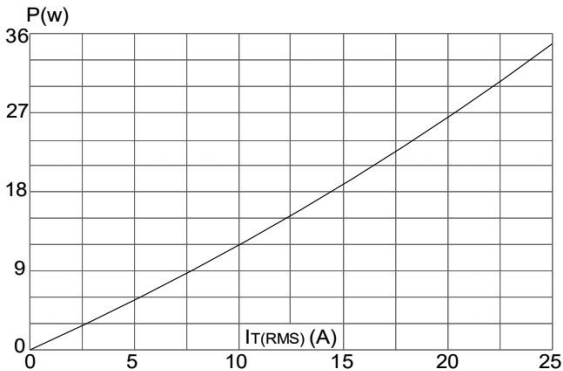

FIG.2: on-state current versus case temperature

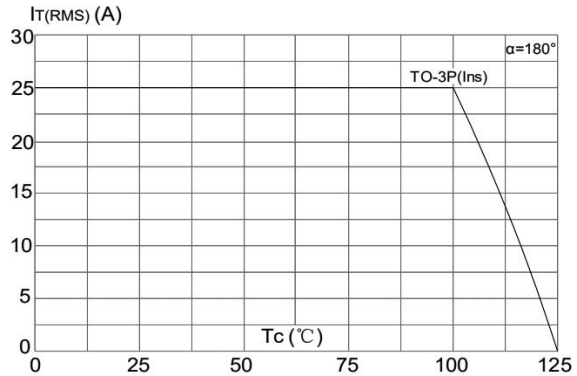

FIG.3: Surge peak on-state current versus number of cycles

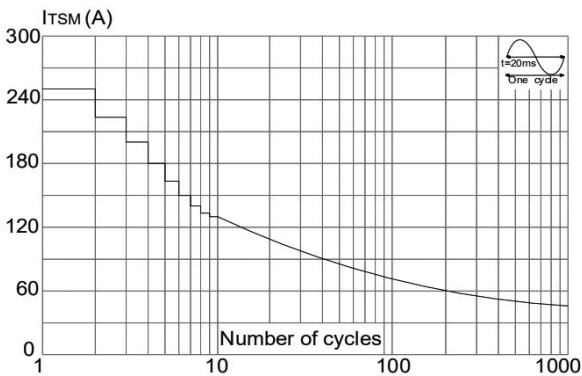

FIG.4: On-state characteristics (maximum values)

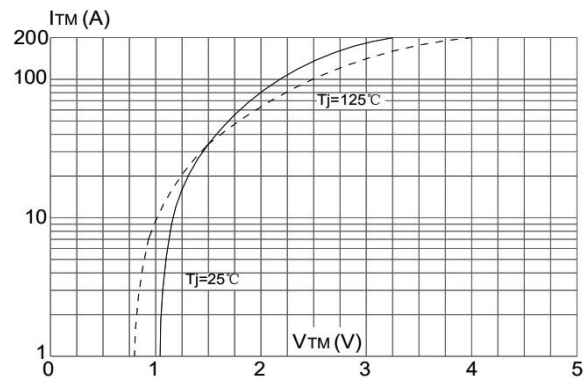

FIG.5: Non-repetitive surge peak on-state current for a sinusoidal pulse with width  $t_p < 10\text{ms}$ , and corresponding value of  $I_2 t$  ( $di/dt < 50\text{A}/\mu\text{s}$ )

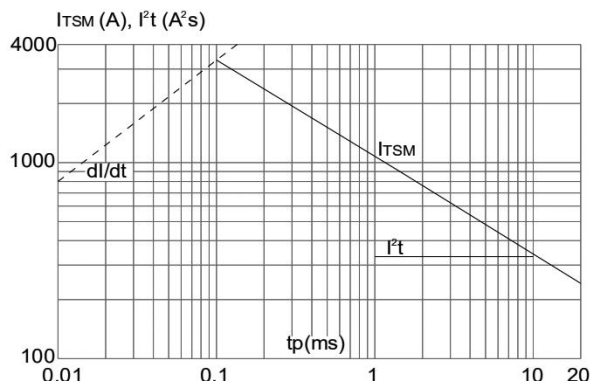

FIG.6: Relative variations of gate trigger current holding current and latching current versus junction temperature

